

Barrier Block Moulds

Interlocking Design To Allow The Creation Of Barrier Walls

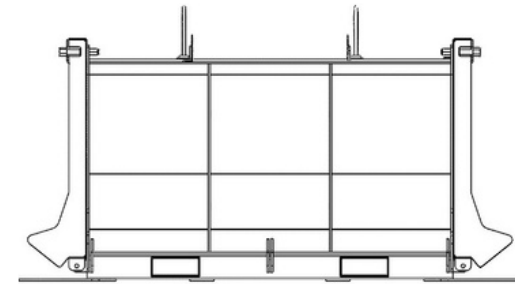
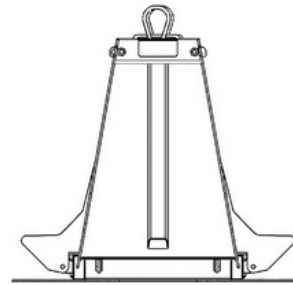
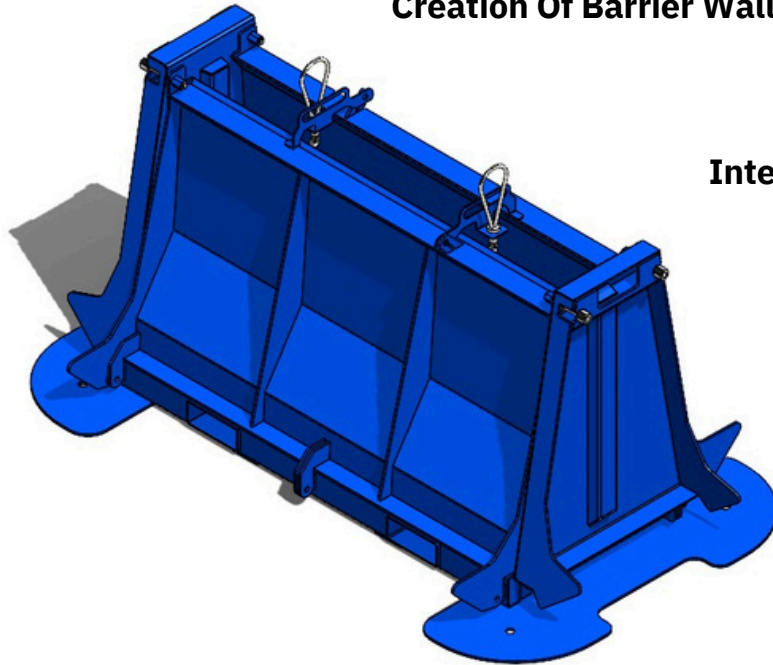

1510L x 590W x 800H

Integrated Fork Slots For Easy Transport

Quick Release System For Splitting Moulds

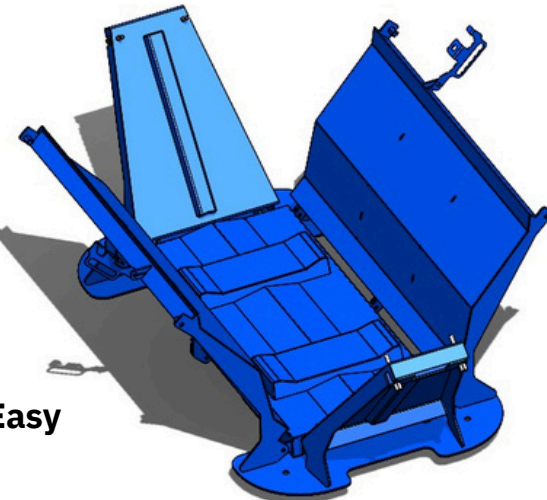

Hinged Sides Allowing Easy Removal Of Blocks

TYPICAL USES OF BLOCKS:

- § Storage Bays For Aggregates / Agricultural / Scrap Merchants,
- § Recycling Centres For Material Segregation,
- § Traffic Calming / Road Barrier,
- § To Provide Security Boundaries

Compatible With:

Other Barrier Blocks

Data for blocks produced from the moulds.

Mould No.	Size / mm	Mass / kg	Volume / m3	No. of Lifting Points
BMB-1510-1	1510	955	0.40	2

Cabragh Engineering